

	operation when directly connected to chimney		operation when connected accumulation mass	
	cupola	hot air exchanger	cupola	adaptor
Energy label	A+	A+	A+	A+
Operating data				
Nominal heat power	8 kW	12 kW	----	----
Efficiency	> 80 %	> 80 %	----	----
Consumption of wood	2,4 kg/h	3,7 kg/h	5,5 kg	5,5 kg
Total heat output of the burning chamber	----	----	21 kW	21 kW
Mass flow of flue gas	8 g/s	11 g/s	20 g/s	20 g/s
Required chimney pressure	12 Pa	12 Pa	12 Pa	15 Pa
Required amount of combustion air	20 m ³ /h	30 m ³ /h	60 m ³ /h	60 m ³ /h
Average flue gas temperature				
on the output	230 °C	275 °C	386 °C	392 °C
past 3,6 m of ceramic accumulation system KMS 300 ¹	----	----	183 °C	----
past accumulation rings (5x acc. ring Ø440mm)	----	----	----	229 °C
Heat distribution				
fireplace insert	62–80 %	62–80 %	40 %	35 %
door glass (single / double)	38 / 20 %	38 / 20 %	38 / 20 %	38 / 20 %
adjoining accumulation mass	----	----	22–40 %	30–45 %
Information for ventilated builds				
Minimal grill area supply / outgoing	900 / 1050 cm ²	1200 / 1400 cm ²	1200 / 1400 cm ²	1200 / 1400 cm ²
Minimum distance from insulated areas / floor	80 / 0 mm		80 / 0 mm	
Reference insulation ² ceiling / back wall / side wall / floor	140 / 100 / 100 / 0 mm		140 / 100 / 100 / 0 mm	
Calciumsilicate insulation ³ ceiling / back wall / side wall / floor	110 / 80 / 80 / 0 mm		110 / 80 / 80 / 0 mm	
Information for non-ventilated builds (closed grills)				
Minimum radiant area ⁴	3,5 m ²		5 m ²	
Minimum distance from insulated areas / floor	80 / 20 mm		80 / 20 mm	
Reference insulation ² ceiling / back wall / side wall / floor	190 / 140 / 140 / 20 mm		190 / 140 / 140 / 20 mm	
Calciumsilicate insulation ³ ceiling / back wall / side wall / floor	140 / 110 / 110 / 20 mm		140 / 110 / 110 / 20 mm	
General technical information				
Total weight / lining weight	ca. 250 / 113 kg		ca. 250 / 113 kg	
Burning chamber dimensions (width x depth)	705 x 305 mm			
Combustion air connection	Ø 125 mm			
Use in non-ventilated accumulation builds according to craft rules	suitable			
Tested according to	EN 13229			
Meets values	1. BlmSchV (Stufe2), 15a BVG, NS 3059			

1 Listed value from testing. For accurate results is evaluation of each system in the Ortner / KOV program necessary.

2 Mineral wool according to AGI-Q 132

3 Example SkamoEnclousure Board 225 kg/m³

4 Depends on accumulation period and material characteristics. Listed values calculated with chamotte stone thickness 30 mm with radiant area 500 W/m²

HAKA 78/57

Technical data
Version 2019/08

hot air exchanger 45°

M 1:10

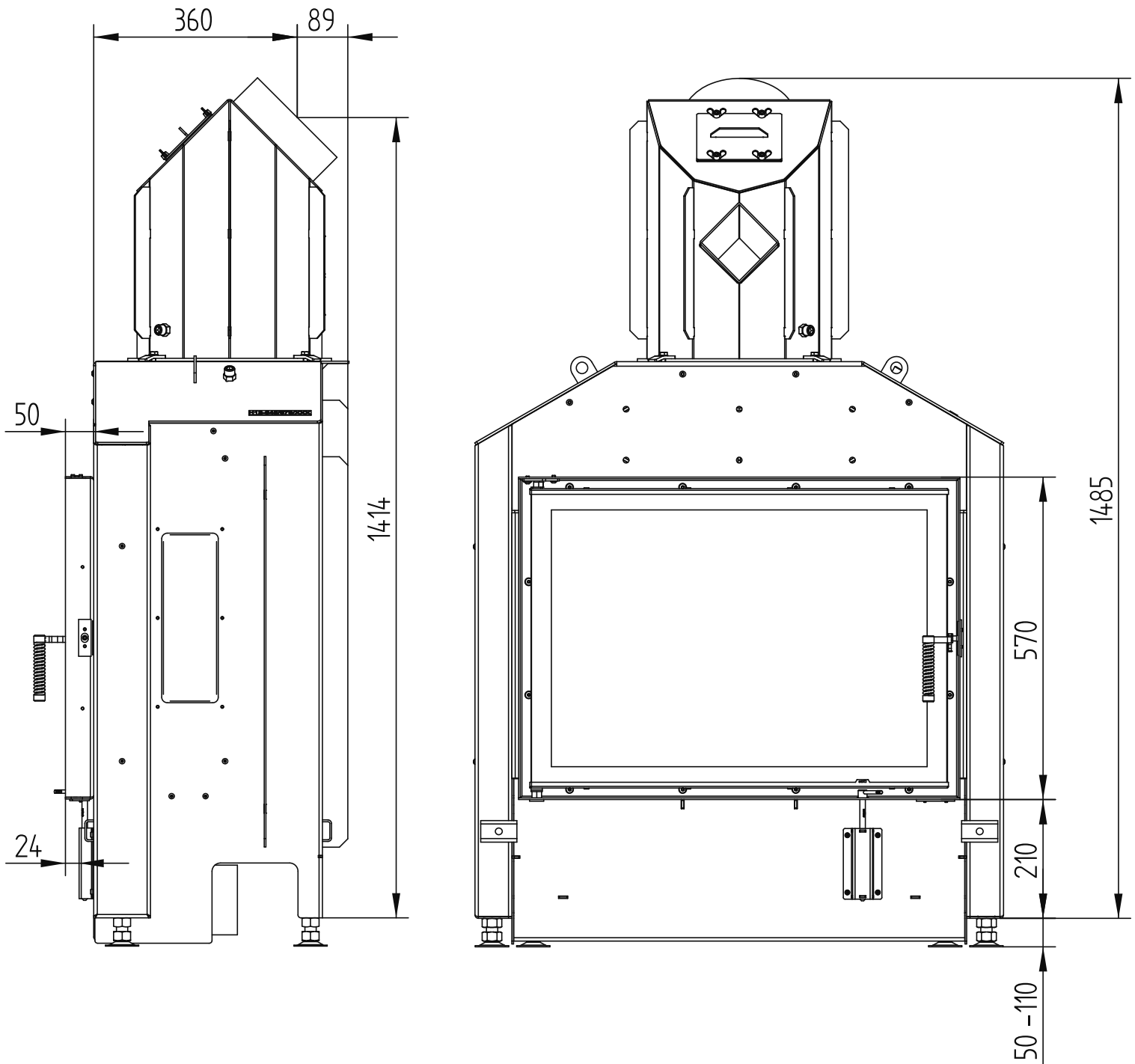

HAKA 78/57

Technical data
Version 2019/08

hot air exchanger 45°

M 1:10

